

< Dual-In-Line Package Intelligent Power Module >

SLIMDIP-S

TRANSFER MOLDING TYPE
INSULATED TYPE

OUTLINE

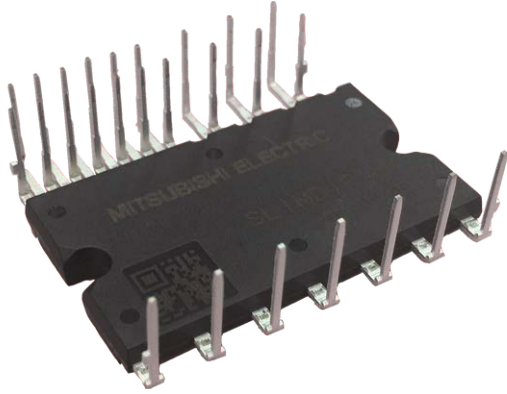

MAIN FUNCTION AND RATINGS

- RC-IGBT inverter bridge for three phase DC-to-AC power conversion
- Built-in bootstrap diodes with current limiting resistor
- Open emitter type

APPLICATION

- AC 100~240V (DC voltage:400V or below) three phase low power motor inverter drive

INTEGRATED DRIVE, PROTECTION AND SYSTEM CONTROL FUNCTIONS

- For P-side : Drive circuit, High voltage high-speed level shifting, Control supply under-voltage protection (UV)
- For N-side : Drive circuit, Control supply under-voltage protection (UV), Short circuit protection (SC), Over temperature protection (OT)
- Fault signaling : Corresponding to SC fault (N-side IGBT), UV fault (N-side supply) and OT fault
- Temperature monitoring : Outputting LVIC temperature by analog signal
- Input interface : Schmitt-triggered 3V, 5V input compatible, high active logic.
- UL Recognized : UL1557 File E323585

INTERNAL CIRCUIT

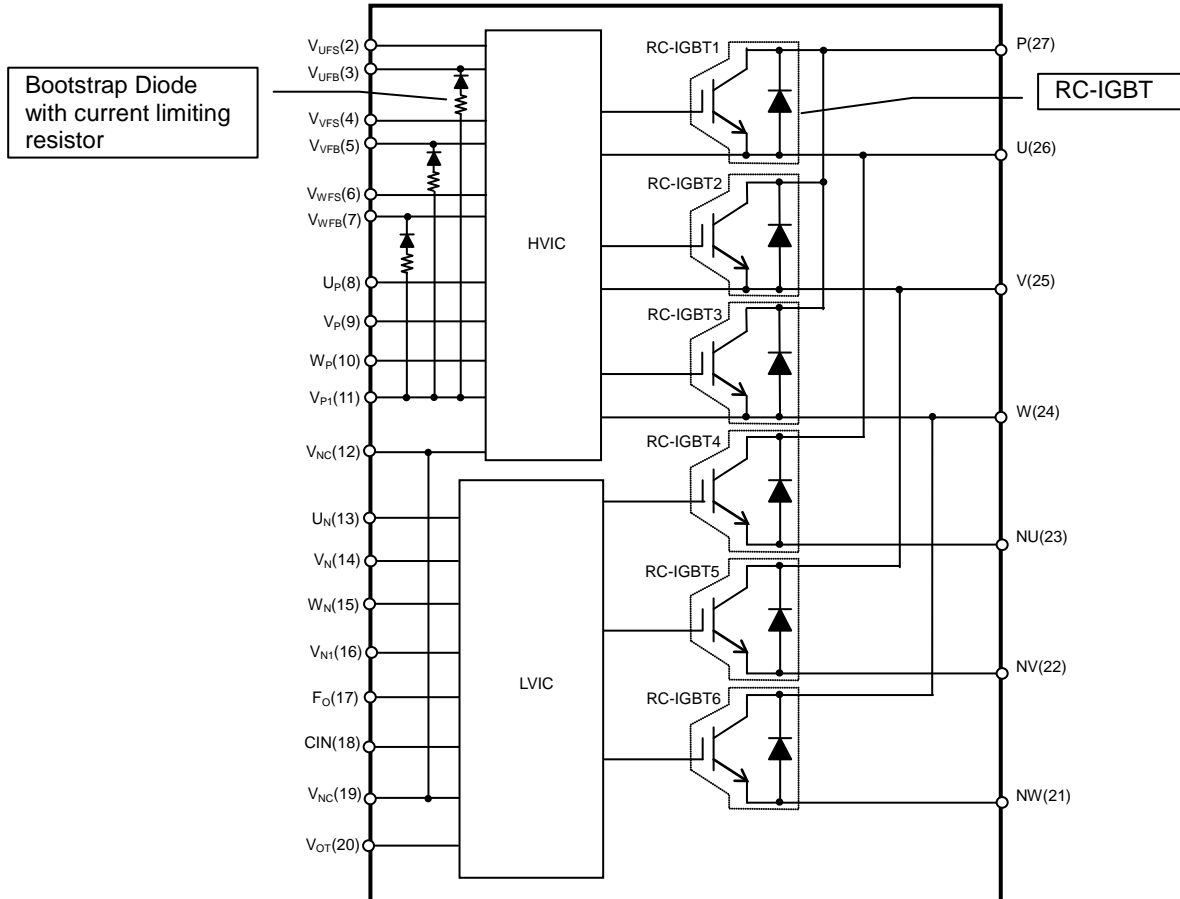

< Dual-In-Line Package Intelligent Power Module >

SLIMDIP-S

TRANSFER MOLDING TYPE
INSULATED TYPE

MAXIMUM RATINGS ($T_j = 25^\circ\text{C}$, unless otherwise noted)

INVERTER PART

Symbol	Parameter	Condition	Ratings	Unit
V_{CC}	Supply voltage	Applied between P-NU, NV, NW	450	V
$V_{CC(\text{surge})}$	Supply voltage (surge)	Applied between P-NU, NV, NW	500	V
V_{CES}	Collector-emitter voltage		600	V
$\pm I_C$	Each IGBT collector current	$T_C = 25^\circ\text{C}$ (Note 1)	5	A
$\pm I_{CP}$	Each IGBT collector current (peak)	$T_C = 25^\circ\text{C}$, less than 1ms	10	A
T_j	Junction temperature		-30~+150	$^\circ\text{C}$

Note1: Pulse width and period are limited due to junction temperature.

CONTROL (PROTECTION) PART

Symbol	Parameter	Condition	Ratings	Unit
V_D	Control supply voltage	Applied between $V_{P1}-V_{NC}$, $V_{N1}-V_{NC}$	20	V
V_{DB}	Control supply voltage	Applied between $V_{UFB}-V_{UFS}$, $V_{VFB}-V_{VFS}$, $V_{WFB}-V_{WFS}$	20	V
V_{IN}	Input voltage	Applied between U_P , V_P , W_P , U_N , V_N , W_N-V_{NC}	-0.5~ $V_D+0.5$	V
V_{FO}	Fault output supply voltage	Applied between F_O-V_{NC}	-0.5~ $V_D+0.5$	V
I_{FO}	Fault output current	Sink current at F_O terminal	1	mA
V_{SC}	Current sensing input voltage	Applied between $CIN-V_{NC}$	-0.5~ $V_D+0.5$	V

TOTAL SYSTEM

Symbol	Parameter	Condition	Ratings	Unit
$V_{CC(\text{PROT})}$	Self protection supply voltage limit (Short circuit protection capability)	$V_D = 13.5\sim 16.5\text{V}$, Inverter Part $T_j = 125^\circ\text{C}$, non-repetitive, less than 2 μs	400	V
T_C	Module case operation temperature	Measurement point of T_C is described in Fig.1 (Note2)	-30~+115	$^\circ\text{C}$
T_{stg}	Storage temperature		-40~+125	$^\circ\text{C}$
V_{iso}	Isolation voltage	60Hz, Sinusoidal, AC 1min, between connected all pins and heat sink plate	2000	V_{rms}

Note2 T_C MEASUREMENT POINT

Fig. 1

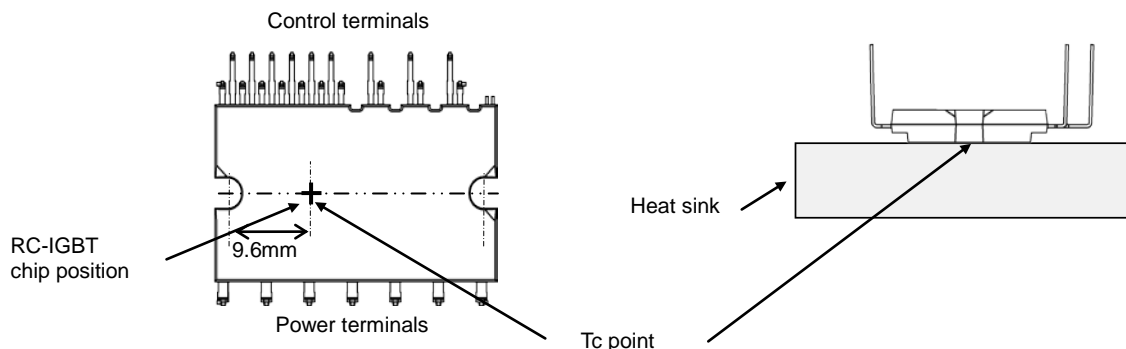

THERMAL RESISTANCE

Symbol	Parameter	Condition	Limits			Unit
			Min.	Typ.	Max.	
$R_{\text{th}(j-c)/Q}$	Junction to case thermal resistance (Note 3)	Inverter RC-IGBT part (per 1/6 module)	-	-	5.4	K/W

Note 3: Grease with good thermal conductivity and long-term endurance should be applied evenly with about +100 μm ~+200 μm on the contacting surface of DIPIPM and heat sink. The contacting thermal resistance between DIPIPM case and heat sink $R_{\text{th}(c-f)}$ is determined by the thickness and the thermal conductivity of the applied grease. For reference, $R_{\text{th}(c-f)}$ is about 0.4K/W (per 1/6 module, grease thickness: 20 μm , thermal conductivity: 1.0W/m \cdot K).

SLIMDIP-S

TRANSFER MOLDING TYPE
INSULATED TYPE

ELECTRICAL CHARACTERISTICS (T_j = 25°C, unless otherwise noted)

INVERTER PART

Symbol	Parameter	Condition	Limits			Unit	
			Min.	Typ.	Max.		
V _{CE(sat)}	Collector-emitter saturation voltage	V _D =V _{DB} = 15V, V _{IN} = 5V	I _C = 5A, T _J = 25°C	-	1.85	2.25	V
			I _C = 5A, T _J = 125°C	-	2.05	2.45	
V _{EC}	FWDi forward voltage	V _{IN} = 0V, -I _C = 5A	-	1.55	1.95	V	
t _{on}	Switching times	V _{CC} = 300V, V _D = V _{DB} = 15V I _C = 5A, T _J = 125°C, V _{IN} = 0→5V Inductive Load (upper-lower arm)	-	0.65	1.05	1.45	μs
t _{C(on)}			-	-	0.30	0.55	μs
t _{off}			-	-	1.15	1.60	μs
t _{C(off)}			-	-	0.15	0.40	μs
t _{rr}			-	-	0.20	-	-
I _{CES}	Collector-emitter cut-off current	V _{CE} =V _{CES}	T _J = 25°C	-	-	1	mA
			T _J = 125°C	-	-	10	

CONTROL (PROTECTION) PART

Symbol	Parameter	Condition	Limits			Unit	
			Min.	Typ.	Max.		
I _D	Circuit current	Total of V _{P1} -V _{NC} , V _{N1} -V _{NC}	V _D =15V, V _{IN} =0V	-	-	3.10	mA
			V _D =15V, V _{IN} =3.3V	-	-	4.20	
			V _D =15V, V _{IN} =5V	-	-	3.10	
		Each part of V _{UFB} -V _{UFS} , V _{VFB} -V _{VFS} , V _{WFB} -V _{WFS}	V _D =V _{DB} =15V, V _{IN} =0V	-	-	0.10	
I _{DB}		V _D =V _{DB} =15V, V _{IN} =5V	-	-	0.10		
V _{SC(ref)}	Short circuit trip level	V _D = 15V (Note 4)	0.455	0.480	0.505	V	
UV _{DBt}	P-side Control supply under-voltage protection(UV)	T _J ≤125°C	Trip level	7.0	10.0	12.0	V
UV _{DBr}			Reset level	7.0	10.0	12.0	V
UV _{Dt}	N-side Control supply under-voltage protection(UV)		Trip level	10.3	-	12.5	V
UV _{Dr}			Reset level	10.8	-	13.0	V
V _{OT}	Temperature Output	Pull down R=5.1kΩ (Note 5)	LVIC Temperature=95°C	2.76	2.89	3.03	V
			LVIC Temperature=25°C	0.86	1.16	1.39	V
OT _t	Over temperature protection (Note6)	V _D = 15V Detect LVIC temperature	Trip level	115	130	145	°C
OT _{rh}			Hysteresis of trip-reset	-	10	-	°C
V _{FOH}	Fault output voltage	V _{SC} = 0V, F _O terminal pulled up to 5V by 10kΩ	4.9	-	-	V	
V _{FOL}		V _{SC} = 1V, I _{F0} = 1mA	-	-	0.95	V	
t _{F0}	Fault output pulse width	(Note 7)	20	-	-	μs	
I _{IN}	Input current	V _{IN} = 5V	0.70	1.00	1.50	mA	
V _{th(on)}	ON threshold voltage	Applied between U _P , V _P , W _P , U _N , V _N , W _N -V _{NC}	-	1.70	2.35	V	
V _{th(off)}	OFF threshold voltage		0.70	1.30	-		
V _{th(hys)}	ON/OFF threshold hysteresis voltage		0.25	0.40	-		
V _F	Bootstrap Di forward voltage	I _F =10mA including voltage drop by limiting resistor (Note 8)	1.1	1.7	2.3	V	
R	Built-in limiting resistance	Included in bootstrap Di	80	100	120	Ω	

Note 4 : SC protection works only for N-side IGBT. Please select the external shunt resistance such that the SC trip-level is less than 1.7 times of the current rating.

5 : Temperature of LVIC vs. V_{OT} output characteristics is described in Fig.3.

6 : When the LVIC temperature exceeds OT trip temperature level(OT_t), OT protection works and Fo outputs. In that case if the heat sink dropped off or fixed loosely, don't reuse that DIPIM. (There is a possibility that junction temperature of power chips exceeded maximum T_J(150°C).

7 : Fault signal Fo outputs when SC, UV or OT protection works. Fo pulse width is different for each protection modes. At SC failure, Fo pulse width is a fixed width (=minimum 20μs), but at UV or OT failure, Fo outputs continuously until recovering from UV or OT state. (But minimum Fo pulse width is 20μs.)

8 : The characteristics of bootstrap Di is described in Fig.2.

Fig. 2 Characteristics of Bootstrap Di V_F-I_F curve (@Ta=25°C) Including Voltage Drop by Limiting Resistor (Right chart is enlarged chart.)

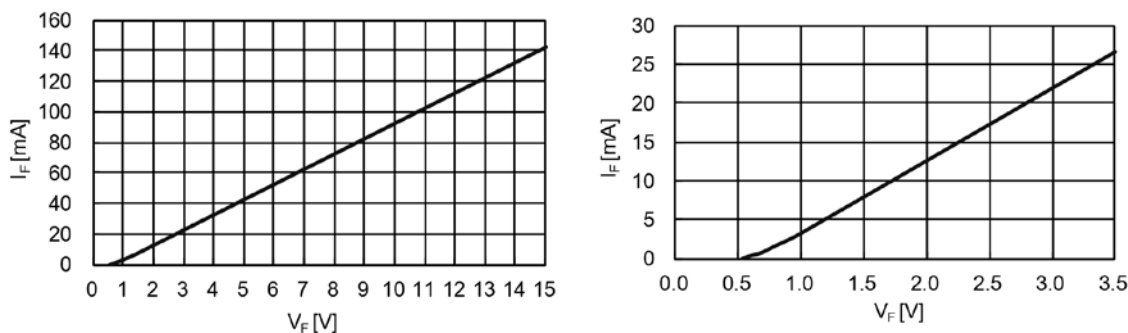

SLIMDIP-S

TRANSFER MOLDING TYPE

INSULATED TYPE

Fig. 3 Temperature of LVIC vs. V_{OT} Output Characteristics

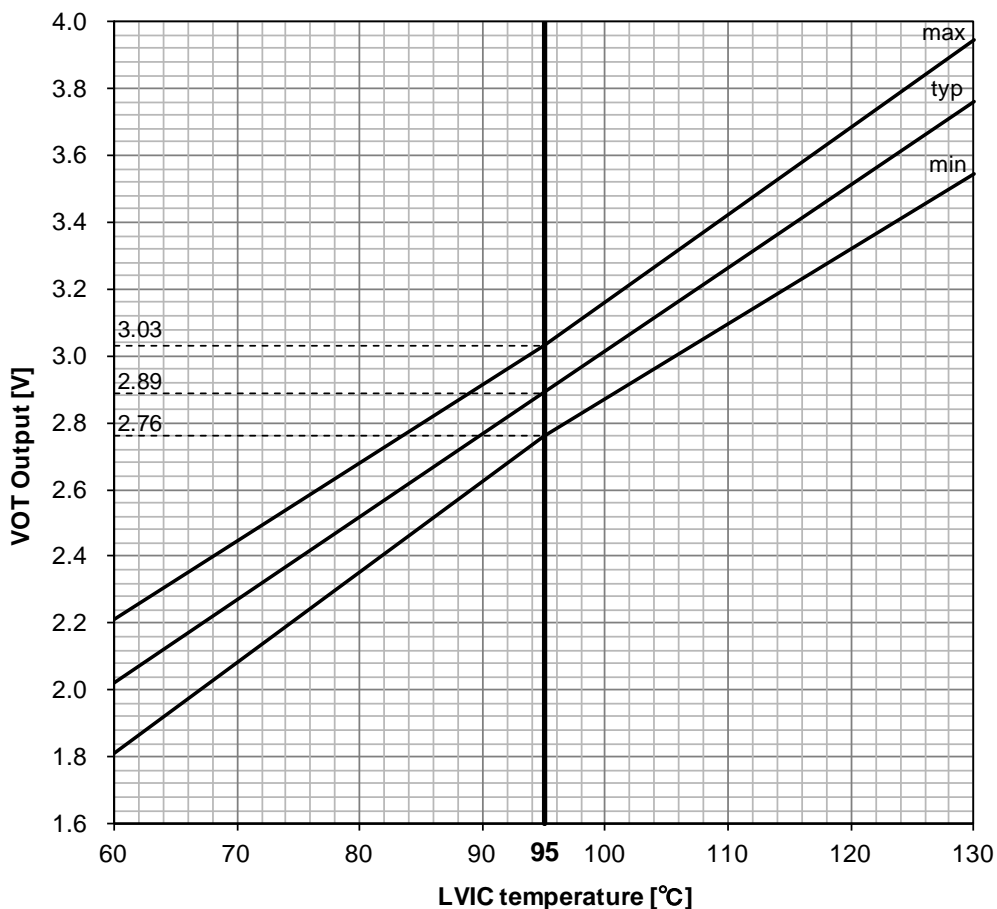
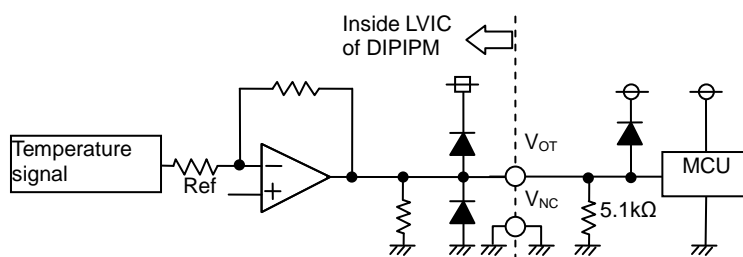

Fig. 4 Pattern Wiring Around the Analog Voltage Output Circuit [V_{OT} terminal]



- (1) V_{OT} outputs the analog signal that is amplified signal of temperature detecting element on LVIC by inverting amplifier.
- (2) It is recommended to insert 5kΩ (5.1kΩ is recommended) pull down resistor for getting linear output characteristics at low temperature below room temperature. When the pull down resistor is inserted between V_{OT} and V_{NC} (control GND), the extra circuit current, which is calculated approximately by V_{OT} output voltage divided by pull down resistance, flows as LVIC circuit current continuously. In the case of using V_{OT} for detecting high temperature over room temperature only, it is unnecessary to insert the pull down resistor.
- (3) In the case of using V_{OT} with low voltage controller like 3.3V MCU, V_{OT} output might exceed control supply voltage 3.3V when temperature rises excessively. If system uses low voltage controller, it is recommended to insert a clamp Di between control supply of the controller and V_{OT} output for preventing over voltage destruction.
- (4) In the case of not using V_{OT} , leave V_{OT} output NC (No Connection).

Refer the application note for SLIMDIP series about the usage of V_{OT} .

SLIMDIP-S

TRANSFER MOLDING TYPE
INSULATED TYPE

MECHANICAL CHARACTERISTICS AND RATINGS

Parameter	Condition		Limits			Unit
			Min.	Typ.	Max.	
Mounting torque	Mounting screw : M3 (Note 9)	Recommended 0.69N·m	0.59	0.69	0.78	N·m
Terminal pulling strength	Control terminal: Load 5N Power terminal: Load 10N	EIAJ-ED-4701	10	-	-	s
Terminal bending strength	Control terminal: Load 2.5N Power terminal: Load 5N 90deg. bend	EIAJ-ED-4701	2	-	-	times
Weight			-	5.5	-	g
Heat radiation part flatness	(Note 10)		-30	-	80	μm

Note 9: Plain washers (ISO 7089-7094) are recommended.

Note 10: Measurement positions of heat radiation part flatness are as below

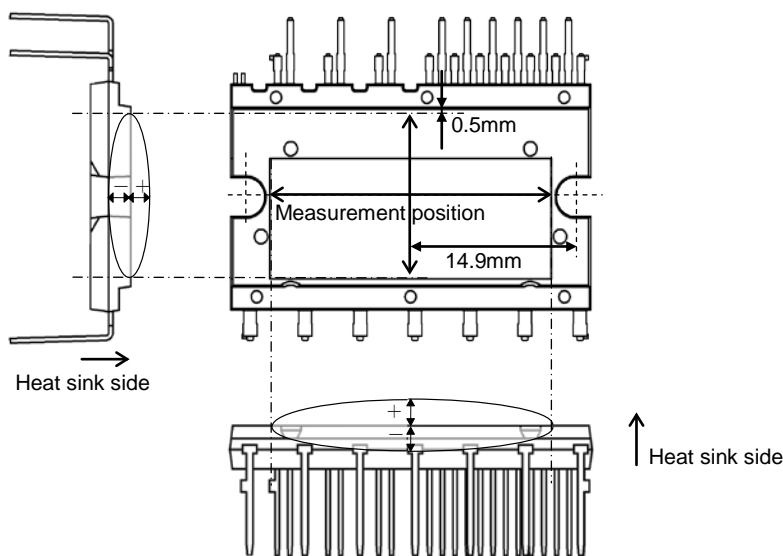

RECOMMENDED OPERATION CONDITIONS

Symbol	Parameter	Condition	Limits			Unit	
			Min.	Typ.	Max.		
V_{CC}	Supply voltage	Applied between P-NU, NV, NW	0	300	400	V	
V_D	Control supply voltage	Applied between $V_{P1}-V_{NC}$, $V_{N1}-V_{NC}$	13.5	15.0	16.5	V	
V_{DB}	Control supply voltage	Applied between $V_{UFB}-V_{UFS}$, $V_{VFB}-V_{VFS}$, $V_{WFB}-V_{WFS}$	13.0	15.0	18.5	V	
$\Delta V_D, \Delta V_{DB}$	Control supply variation		-1	-	+1	V/μs	
t_{dead}	Arm shoot-through blocking time	For each input signal, $T_C \leq 100^\circ\text{C}$	1.0	-	-	μs	
f_{PWM}	PWM input frequency	$T_C \leq 100^\circ\text{C}$, $T_j \leq 125^\circ\text{C}$	-	-	20	kHz	
I_o	Allowable r.m.s. current	$V_{CC} = 300\text{V}$, $V_D = V_{DB} = 15\text{V}$, P.F = 0.8, Sinusoidal PWM $T_C \leq 100^\circ\text{C}$, $T_j \leq 125^\circ\text{C}$ (Note 11)	$f_{PWM} = 5\text{kHz}$	-	-	2.5	Arms
			$f_{PWM} = 15\text{kHz}$	-	-	2.0	
$P_{WIN(on)}$	Minimum input pulse width	(Note 12)	0.7	-	-	μs	
$P_{WIN(off)}$			0.7	-	-		
V_{NC}	V_{NC} variation	Between $V_{NC}-\text{NU}$, NV, NW (including surge)	-5.0	-	+5.0	V	
T_j	Junction temperature		-20	-	+125	°C	

Note 11: Allowable r.m.s. current depends on the actual application conditions.

12: DIIPM might not make response if the input signal pulse width is less than $P_{WIN(on)}$, $P_{WIN(off)}$.

SLIMDIP-S

TRANSFER MOLDING TYPE
INSULATED TYPE

Fig. 5 Timing Charts of The DIIPM Protective Functions

[A] Short-Circuit Protection (N-side only with the external shunt resistor and RC filter)

- a1. Normal operation: IGBT ON and outputs current.
- a2. Short circuit current detection (SC trigger)
(It is recommended to set RC time constant 1.5~2.0μs so that IGBT shut down within 2.0μs when SC.)
- a3. All N-side IGBT's gates are hard interrupted.
- a4. All N-side IGBTs turn OFF.
- a5. Fo outputs for t_{Fo} =minimum 20μs.
- a6. Input = "L": IGBT OFF
- a7. Fo finishes output, but IGBTs don't turn on until inputting next ON signal (L→H).
- (IGBT of each phase can return to normal state by inputting ON signal to each phase.)
- a8. Normal operation: IGBT ON and outputs current.

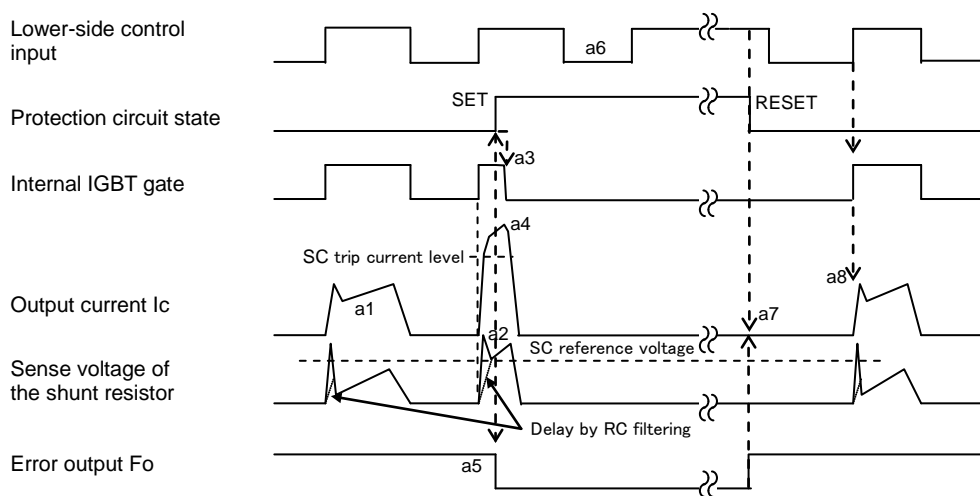

[B] Under-Voltage Protection (N-side, UV_D)

- b1. Control supply voltage V_D exceeds under voltage reset level (UV_{Dr}), but IGBT turns ON by next ON signal (L→H).
(IGBT of each phase can return to normal state by inputting ON signal to each phase.)
- b2. Normal operation: IGBT ON and outputs current.
- b3. V_D level drops to under voltage trip level. (UV_{Dt}).
- b4. All N-side IGBTs turn OFF in spite of control input condition.
- b5. Fo outputs for t_{Fo} =minimum 20μs, but output is extended during V_D keeps below UV_{Dr} .
- b6. V_D level reaches UV_{Dr} .
- b7. Normal operation: IGBT ON and outputs current.

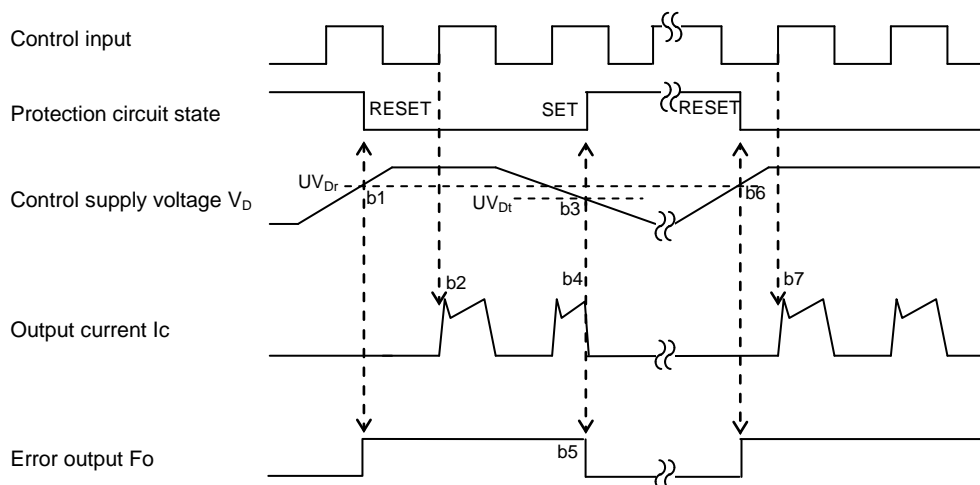

SLIMDIP-S

TRANSFER MOLDING TYPE

INSULATED TYPE

[C] Under-Voltage Protection (P-side, UV_{DB})

- c1. Control supply voltage V_{DB} rises. After the voltage reaches under voltage reset level UV_{DBr} , IGBT turns on by next ON signal (L→H).
- c2. Normal operation: IGBT ON and outputs current.
- c3. V_{DB} level drops to under voltage trip level (UV_{DBt}).
- c4. IGBT of the corresponding phase only turns OFF in spite of control input signal level, but there is no F_o signal output.
- c5. V_{DB} level reaches UV_{DBr} .
- c6. Normal operation: IGBT ON and outputs current.

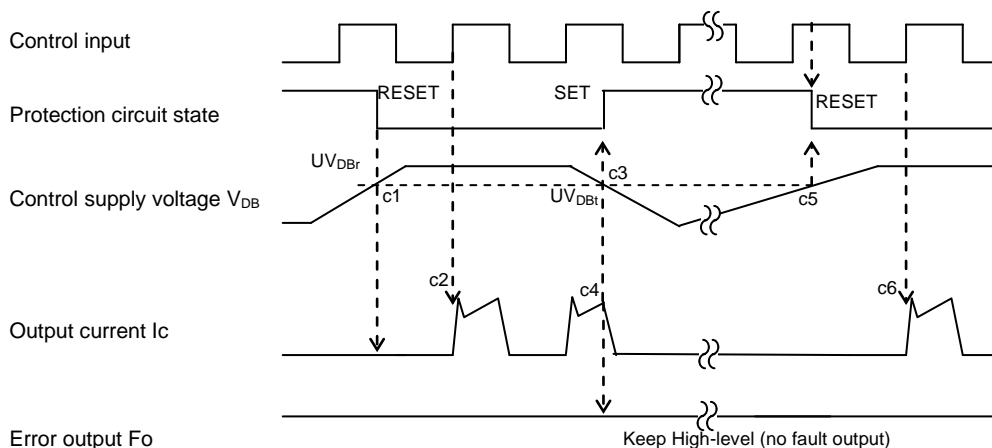

[D] Over Temperature Protection (N-side, Detecting LVIC temperature)

- d1. Normal operation: IGBT ON and outputs current.
- d2. LVIC temperature exceeds over temperature trip level (OT_t).
- d3. All N-side IGBTs turn OFF in spite of control input condition.
- d4. F_o outputs for t_{Fo} =minimum 20 μ s, but output is extended during LVIC temperature keeps over OT_t .
- d5. LVIC temperature drops to over temperature reset level.
- d6. Normal operation: IGBT turns on by next ON signal (L→H).

(IGBT of each phase can return to normal state by inputting ON signal to each phase.)

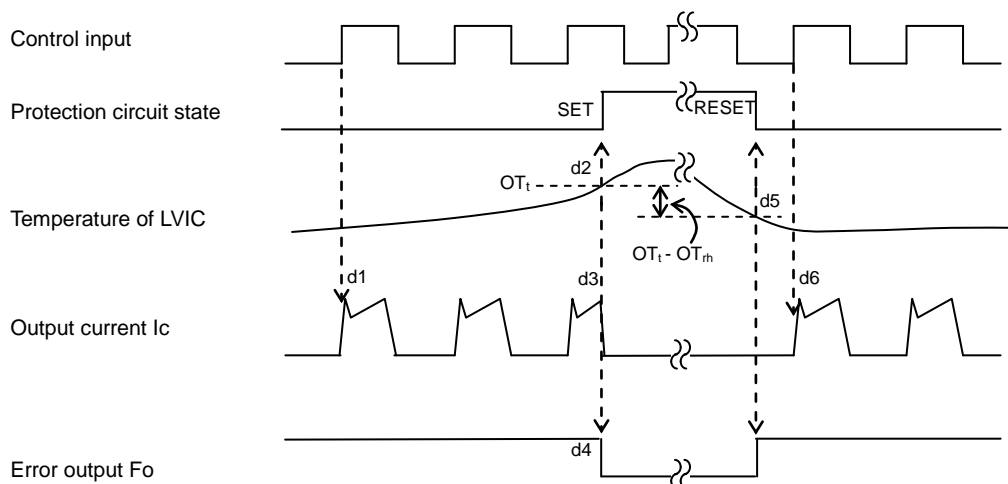

SLIMDIP-S

TRANSFER MOLDING TYPE

INSULATED TYPE

Fig. 6 Example of Application Circuit

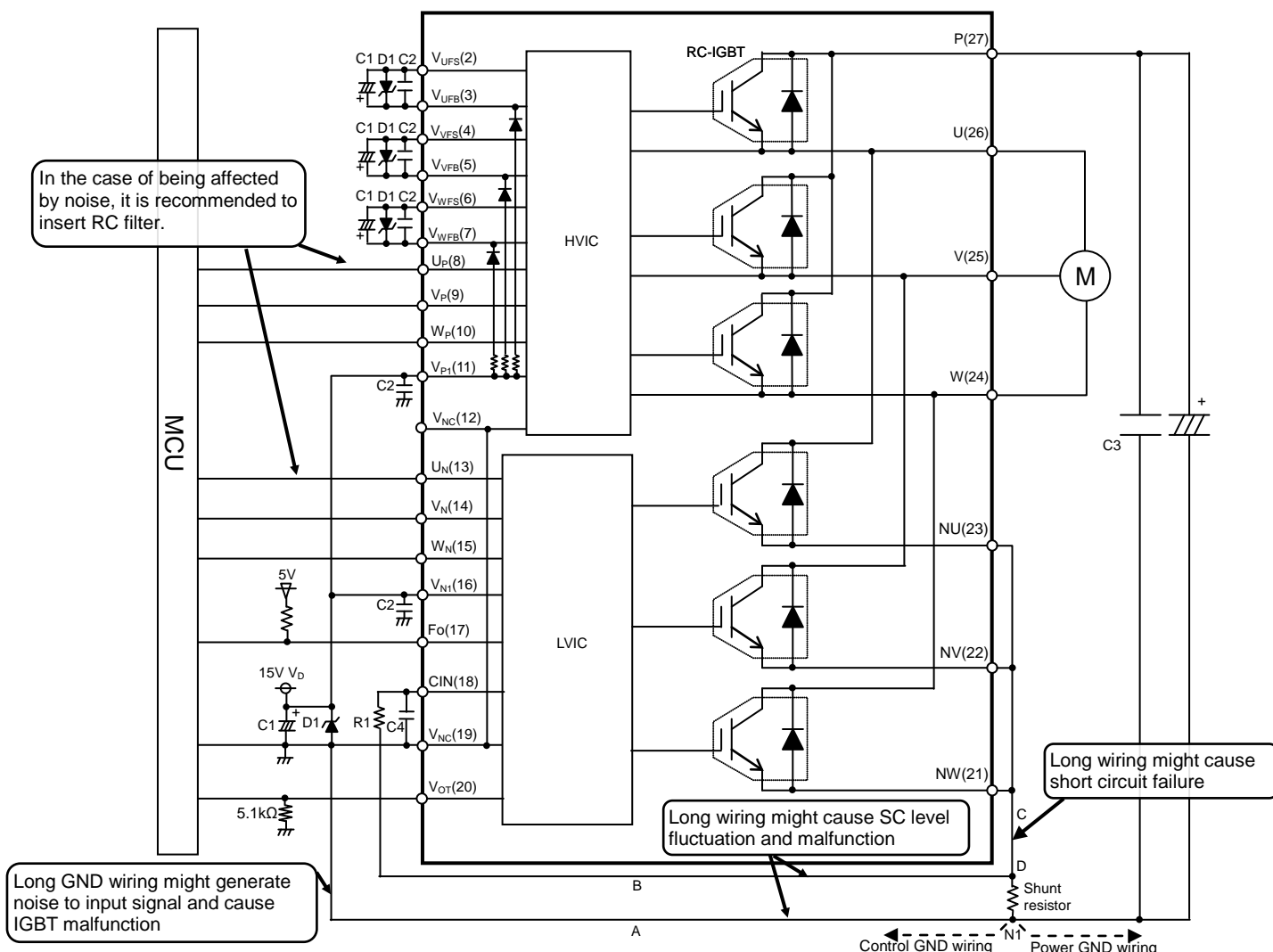

- (1) If control GND is connected with power GND by common broad pattern, it may cause malfunction by power GND fluctuation. It is recommended to connect control GND and power GND at only a point N1 (near the terminal of shunt resistor).
- (2) It is recommended to insert a Zener diode D1 (24V/1W) between each pair of control supply terminals to prevent surge destruction.
- (3) To prevent surge destruction, the wiring between the smoothing capacitor and the P, N1 terminals should be as short as possible. Generally a 0.1-0.22μF snubber capacitor C3 between the P-N1 terminals is recommended.
- (4) R1, C4 of RC filter for preventing protection circuit malfunction is recommended to select tight tolerance, temp-compensated type. The time constant R1C4 should be set so that SC current is shut down within 2μs. (1.5μs~2μs is general value.) SC interrupting time might vary with the wiring pattern, so the enough evaluation on the real system is necessary.
- (5) To prevent malfunction, the wiring of A, B, C should be as short as possible.
- (6) The point D at which the wiring to CIN filter is divided should be near the terminal of shunt resistor. NU, NV, NW terminals should be connected at near NU, NV, NW terminals.
- (7) All capacitors should be mounted as close to the terminals as possible. (C1: good temperature, frequency characteristic electrolytic type and C2:0.01μ-2μF, good temperature, frequency and DC bias characteristic ceramic type are recommended.)
- (8) Input drive is High-active type. There is a minimum 3.3kΩ pull-down resistor in the input circuit of IC. To prevent malfunction, the wiring of each input should be as short as possible. When using RC coupling circuit, make sure the input signal level meet the turn-on and turn-off threshold voltage.
- (9) Thanks to built-in HVIC, direct coupling to MCU without any optocoupler or transformer isolation is possible.
- (10) Fo output is open drain type. It should be pulled up to MCU or control power supply (e.g. 5V,15V) by a resistor that makes I_{FO} up to 1mA. (I_{FO} is estimated roughly by the formula of control power supply voltage divided by pull-up resistance. In the case of pulled up to 5V, 10kΩ (5kΩ or more) is recommended.)
- (11) Two V_{NC} terminals are connected inside DIPIMP, please connect either one to the 15V power supply GND outside and leave another one open.
- (12) If high frequency noise superimposed to the control supply line, IC malfunction might happen and cause DIPIMP erroneous operation. To avoid such problem, line ripple voltage should meet dV/dt ≤±/1V/μs, V_{ripple}≤2Vp-p.

SLIMDIP-S

TRANSFER MOLDING TYPE
INSULATED TYPE

Fig. 7 MCU I/O Interface Circuit

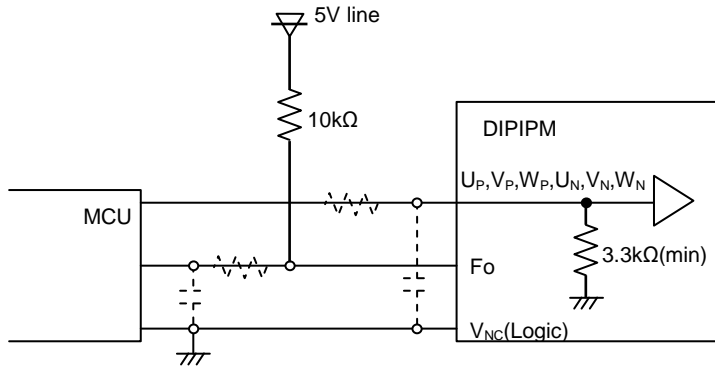

Note: The RC coupling (parts shown in the dotted line) at each input depends on user's PWM control strategy and the wiring impedance of the printed circuit board. The DIPIPM signal input section integrates a 3.3kΩ(min) pull-down resistor. Therefore, when using an external filtering resistor, please pay attention to the signal voltage drop at input terminal.

Fig. 8 Pattern Wiring Around the Shunt Resistor

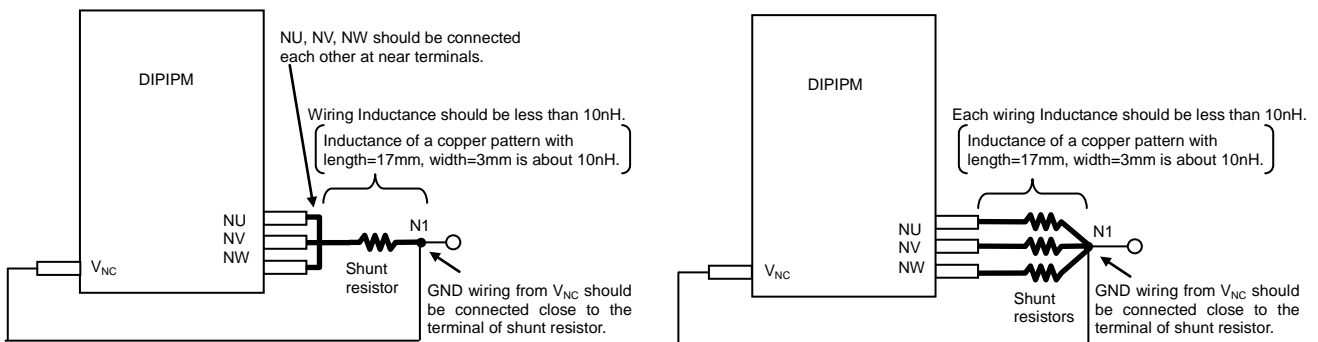

Low inductance shunt resistor like surface mounted (SMD) type is recommended.

Fig. 9 External SC Protection Circuit with Using Three Shunt Resistors

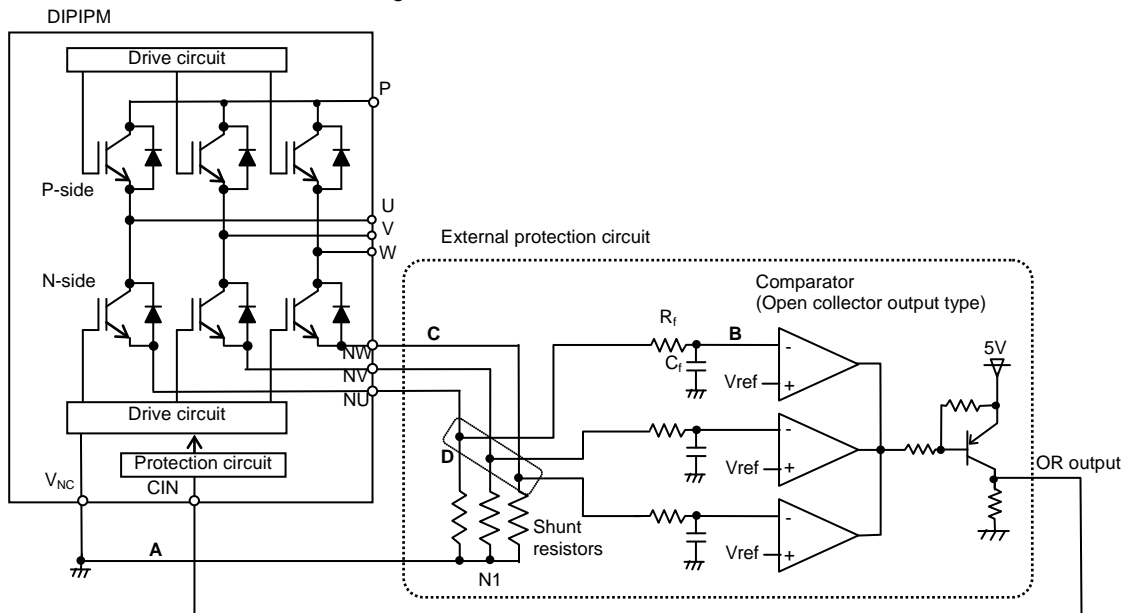

- (1) It is necessary to set the time constant $R_f C_f$ of external comparator input so that IGBT stop within $2\mu s$ when short circuit occurs. SC interrupting time might vary with the wiring pattern, comparator speed and so on.
- (2) The threshold voltage V_{ref} should be set up the same rating of short circuit trip level ($V_{sc(ref)}$ typ. 0.48V).
- (3) Select the external shunt resistance so that SC trip-level is less than specified maximum value.
- (4) To avoid malfunction, the wiring A, B, C should be as short as possible.
- (5) The point D at which the wiring to comparator is divided should be near the terminal of shunt resistor.
- (6) OR output high level should be over 0.505V (=maximum $V_{sc(ref)}$).
- (7) GND of Comparator, V_{ref} circuit and C_f should be not connected to noisy power GND but to control GND wiring.

SLIMDIP-S

TRANSFER MOLDING TYPE

INSULATED TYPE

Fig. 10 Package Outlines

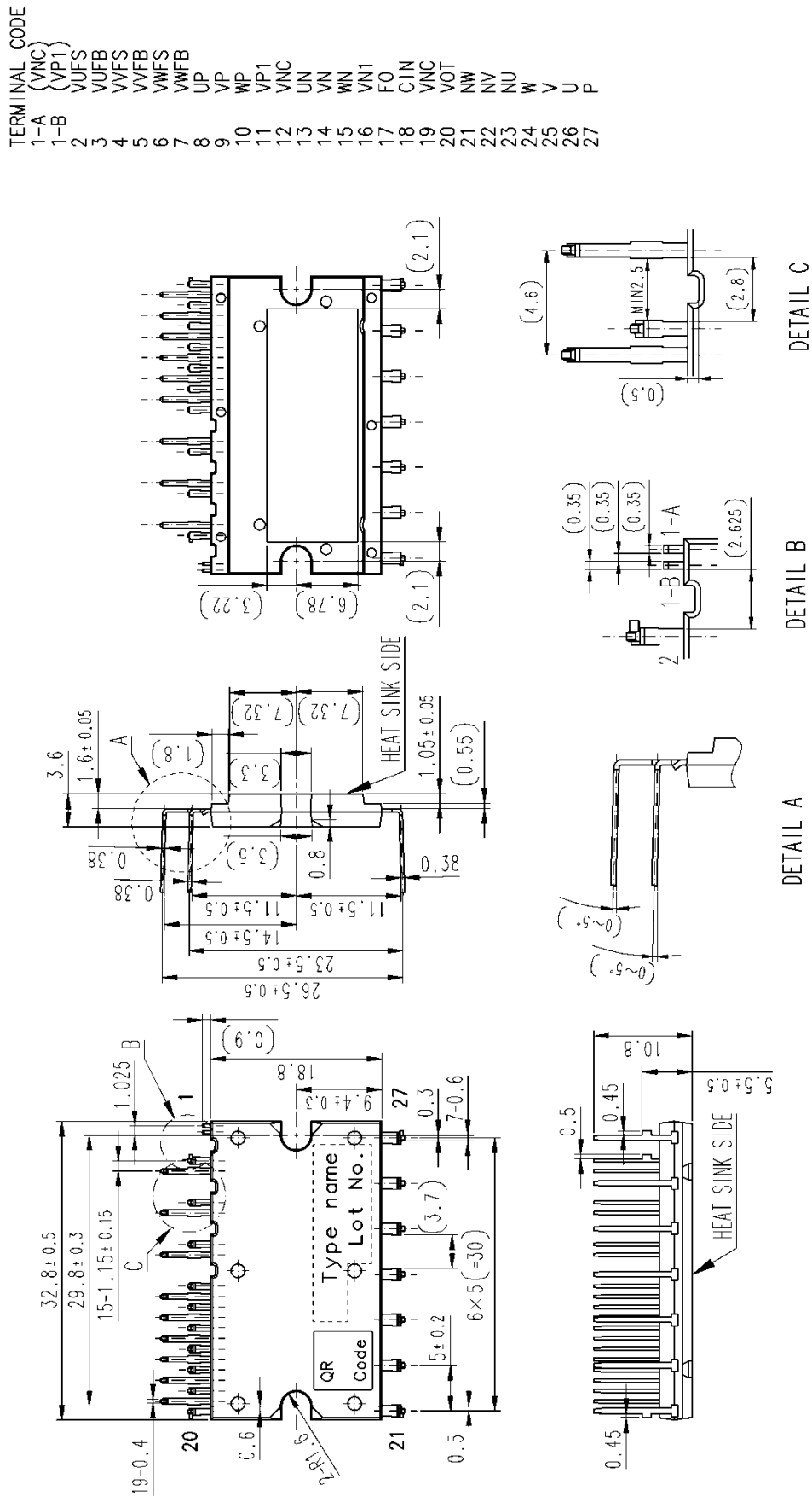

Note: Connect only one V_{NC} terminal (No.12 or 19) to the system GND and leave another one open.
 QR Code is registered trademark of DENSO WAVE INCORPORATED in JAPAN and other countries.

< Dual-In-Line Package Intelligent Power Module >

SLIMDIP-S

TRANSFER MOLDING TYPE

INSULATED TYPE

Revision Record

Rev.	Date	Page	Revised contents
1	20/04/2016	-	New

SLIMDIP-S

TRANSFER MOLDING TYPE

INSULATED TYPE

Keep safety first in your circuit designs!

Mitsubishi Electric Corporation puts the maximum effort into making semiconductor products better and more reliable, but there is always the possibility that trouble may occur with them. Trouble with semiconductors may lead to personal injury, fire or property damage. Remember to give due consideration to safety when making your circuit designs, with appropriate measures such as (i) placement of substitutive, auxiliary circuits, (ii) use of non-flammable material or (iii) prevention against any malfunction or mishap.

Notes regarding these materials

- These materials are intended as a reference to assist our customers in the selection of the Mitsubishi semiconductor product best suited to the customer's application; they do not convey any license under any intellectual property rights, or any other rights, belonging to Mitsubishi Electric Corporation or a third party.
- Mitsubishi Electric Corporation assumes no responsibility for any damage, or infringement of any third-party's rights, originating in the use of any product data, diagrams, charts, programs, algorithms, or circuit application examples contained in these materials.
- All information contained in these materials, including product data, diagrams, charts, programs and algorithms represents information on products at the time of publication of these materials, and are subject to change by Mitsubishi Electric Corporation without notice due to product improvements or other reasons. It is therefore recommended that customers contact Mitsubishi Electric Corporation or an authorized Mitsubishi Semiconductor product distributor for the latest product information before purchasing a product listed herein.

The information described here may contain technical inaccuracies or typographical errors. Mitsubishi Electric Corporation assumes no responsibility for any damage, liability, or other loss rising from these inaccuracies or errors.

Please also pay attention to information published by Mitsubishi Electric Corporation by various means, including the Mitsubishi Semiconductor home page (<http://www.MitsubishiElectric.com/>).

- When using any or all of the information contained in these materials, including product data, diagrams, charts, programs, and algorithms, please be sure to evaluate all information as a total system before making a final decision on the applicability of the information and products. Mitsubishi Electric Corporation assumes no responsibility for any damage, liability or other loss resulting from the information contained herein.
- Mitsubishi Electric Corporation semiconductors are not designed or manufactured for use in a device or system that is used under circumstances in which human life is potentially at stake. Please contact Mitsubishi Electric Corporation or an authorized Mitsubishi Semiconductor product distributor when considering the use of a product contained herein for any specific purposes, such as apparatus or systems for transportation, vehicular, medical, aerospace, nuclear, or undersea repeater use.
- The prior written approval of Mitsubishi Electric Corporation is necessary to reprint or reproduce in whole or in part these materials.
- If these products or technologies are subject to the Japanese export control restrictions, they must be exported under a license from the Japanese government and cannot be imported into a country other than the approved destination.
Any diversion or re-export contrary to the export control laws and regulations of Japan and/or the country of destination is prohibited.
- Please contact Mitsubishi Electric Corporation or an authorized Mitsubishi Semiconductor product distributor for further details on these materials or the products contained therein.